



## Ontario Double Square Granite Kitchen Sink Black

SKU#: K-0219

**\$319.20**

~~\$399~~

### KITCHEN TAP OPTION

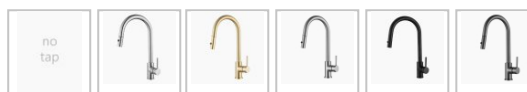

### KITCHEN WASTE OPTION



### ACCESSORIES OPTION



Length: 780mm

Width: 450mm

Height: 215mm

Capacity: 27L/27L

Waste: Standard Waste Included

Material: Granite stone composite (80% granite)

Configuration: 2 Double sinks, overmount or undermount (fittings included)

Warranty: 5 Year Product Warranty

The Ontario square sink is an elegant and stylish addition to your kitchen. The black granite adds a modern touch while still remaining functional.

Granite is a beneficial choice as it is scratch, stain and heat resistant. Its durability is sure to last in your kitchen. It can be installed topmount or undermount to achieve the look you desire.

Suits: *Toronto Chopping Board (A-3002)*

View our store for our range of [taps](#) to complete the look.

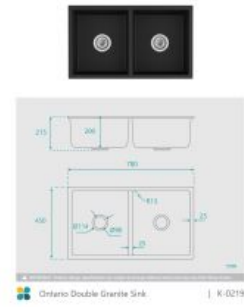

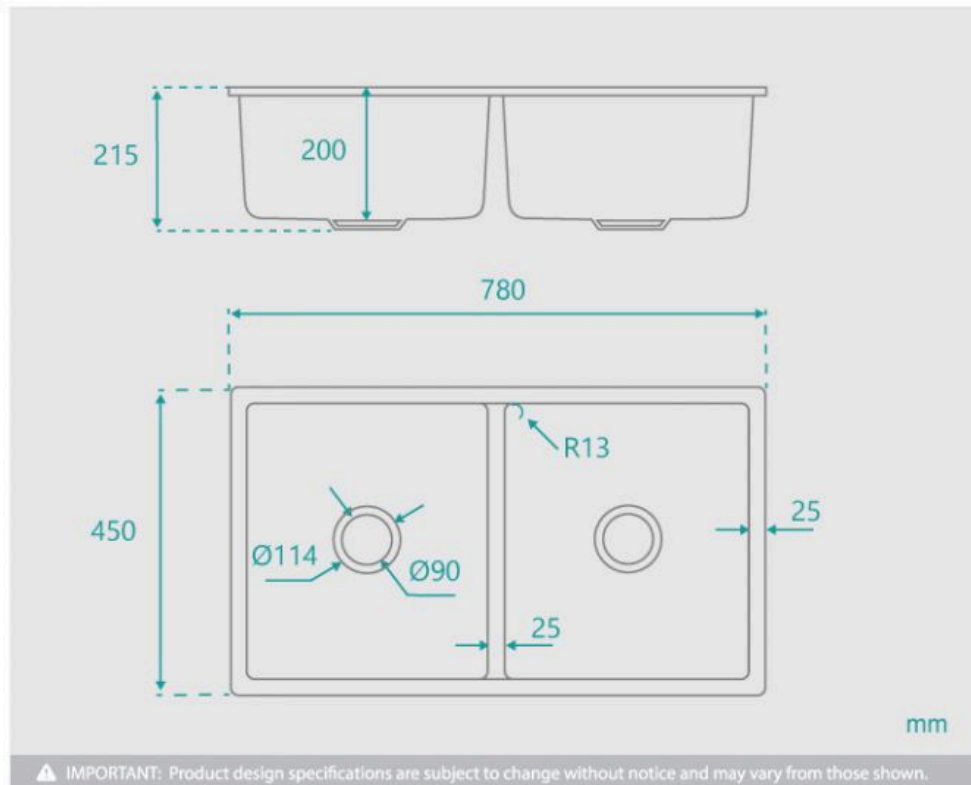

Ontario Double Granite Sink

| K-0219